



Snowmelt Systems Installers Handbook 2005

Revised July 2005

Snowmelt Systems — Installer's Handbook

by

Roth Industries, Inc.

Revised 2005 — All Rights Reserved

US Office:

Roth Industries, Inc.
77 Circuit Drive
North Kingstown, RI 02852
Phone: 401.267.9044
Toll Free: 888.316.7684
Fax: 401.267.9048
Website: www.roth-usa.com
E-mail: info@roth-usa.com

Canadian Office:

Roth Canada
1607 Rue de l'Industrie
Beloeil, QC J3G 4S5
Phone: 450.464.1329
Toll Free: 800.969.7684
Fax: 450.464.7950
Website: www.roth-canada.com
E-mail: service@roth-canada.com

TABLE OF CONTENT

1. INITIAL CONSIDERATIONS

Snowmelt Design4
 Zoning the System4
 Control Strategy5
 Insulation5
 Drainage5
 Loop Patterns6

2. SYSTEM DESIGN

Total System Btu/hr Capacity6
 Total Flow Rate6
 Tubing Selection7
 Total Tubing and Number of Loops Required7
 Manifold Selection and Location7
 Pumps, Expansion Tanks and Other Accessories8
 Equipment Size8
 Tubing Selection8

3. EXAMPLE CALCULATION

Loop Head Loss9
 Manifold Location9
 Expansion Tanks and Other Accessories9
 Controls10
 Head Loss by Loop Length and Btuh/sq.ft.
 for 5/8" and 3/4" pex with 10"
 Tube Spacing (100°F Water)11
 Head Loss by Loop Length and Btuh/sq.ft.
 for 5/8" and 3/4" pex with 6"
 Tube Spacing (100°F Water)12
 Head Loss Correction Factors
 for Propylene Glycol by Concentration
 and Average Temperature13

4. SAMPLE INSTALLATION — CROSS SECTIONS

Concrete14
 Asphalt14
 Paver14

5. SUMMARY

1. INITIAL CONSIDERATIONS

Snowmelt Design

Snowmelt systems are one of the fastest growing applications of hydronic radiant heating. These systems are installed for both convenience, such as residential driveway and walkway melting, and for necessity, such as keeping emergency access areas clear of snow and ice under all conditions. When you have the correct information these systems are relatively easy to design and install. The Roth Design Software has a snowmelt module included in the package to automate this process, including drawing the melt area with loops and manifolds. Our software helps to make the process simple but the following information is offered to give you a better understanding of the process and the ability to do manual calculations when needed. These guidelines are not exact, but will get you very close to the computed results.

System Capacity: When designing snowmelt applications, the first and most important step is determining the requirements and expectations of the customer. Snowmelt systems are neither inexpensive to install or operate and system performance has the largest impact on the initial installation cost and long-term operating costs. It may not make sense to have a residential system that can keep up with the "100 year" snowfall, but it can only create problems to design a system for emergency access that can only work "most of the time". Be sure to discuss the temperatures the system is designed to function within and when the system will not be able to keep up with load and should be shut down. A system that is not able to keep up with the load may actually cause ice formation due to partial melting and re-freezing.

It is important to know the snow conditions for the area where the system will be installed. In some areas it will usually stop snowing at between +15°F and +20°F, and when it does snow, the snow will be dry and blow easily. In these areas it may not make much sense to design systems that can perform below +10°F with a 10 mph wind. In other areas with "lake effect" snow, it can snow at much lower temperatures and at a greater rate and the snow can be much heavier and more difficult to melt. In these areas it may be reasonable to design for more harsh weather conditions.

The next most important concern is the system reaction time. This is the amount of time it takes to bring the surface up to the melting point, usually 38-40°F. If you have an area that needs to be "frost free", the system should be set to keep the surface "idling" at a temperature below the melting point but close enough so the system can come up to the melting temperature quickly enough to prevent frost. These systems are

expensive to operate because you are constantly maintaining temperature in anticipation of possible snow or frost. Idling temperatures vary by the project, but typically will be between 20°F and 30°F, depending on the time it takes to reach melting temperature and how much frost or snow accumulation is acceptable. If a system is properly designed and installed, idling may not be necessary, except for areas that need to clear under all conditions.

Zoning the System

You should always look at a snowmelt system the same as any other heating system: arrange for the system to operate as separate, logical zones. If you design and install the system in this manner you can get more effective and economic performance from the system. Break the system down into three categories during the design phase: (1) high priority areas that absolutely have to clear under all conditions, (2) medium priority areas that are important to keep clear but not absolutely necessary and (3) low priority areas that are not essential to have clear but if the capacity exists it can be used for this purpose. When the system is installed in this manner sections can be cut out for economic reasons without eliminating the areas that drove the installation of the system in the beginning. You can also use a limited amount of capacity from an existing heating plant for snowmelt. The heating plant can be designed to cover the high priority area under the worst expected conditions requiring a very high Btuh/sq.ft. output without any additional loads. As the conditions improve you can add the medium priority and then the low priority zones into the load. These zones can be added automatically or manually depending on what the customer needs.

1. INITIAL CONSIDERATIONS

The important thing about designing with zones in mind is that the customer can control the amount of energy spent on melting and can eliminate non-critical areas without shutting down the entire system. Snowmelt systems that do not have zoning capability become an "all or nothing" system and are most often shut down and abandoned because the operating expense is too high or use patterns have changed.

Control Strategy

The control strategy you select can make a major impact on the convenience and operating costs of a snowmelt system. Manual "On-Off" systems require a person to start the system in the event of snowfall. If nobody is there to turn the system on, snow will accumulate. If the system is started too late it will take extra time to begin melting. If the operator forgets to turn the system off after a snowfall they may be shocked by their fuel bill. "Fully Automatic" controls can start the system when it is actually snowing or in danger of frost and shut the system down when the conditions no longer warrant system operation. They can also maintain an idle temperature (if needed), protect your heating plant and slab from thermal shock, exercise pumps and control valves and provide the safest and most efficient system available. These systems are more expensive initially but can save on operating expense and provide much more convenience.

Insulation

Insulation under the melting surface and around the perimeter edge can provide substantial savings during operation and should always be considered for any snowmelt project. Often, insulation can make the difference between whether a system needs to idle, maintaining a surface temperature just below freezing all winter long, regardless of whether snow is present, or if it can just start up when there is actual snow or frost. A well insulated slab can get to melt temperature quickly and greatly reduce the "downward" losses (heating the earth underneath the slab). A slab without insulation can require about 33% more energy to compensate for these losses and the time required to reach melt temperature may make the system impossible to operate without maintaining an idling temperature. In almost all cases, the savings in operating costs will offset

the cost of the insulation. 1" to 2" thick foam board, the same as when installing radiant heat in a residence, is a wise investment. "High Load" foam board (100 psi) is available for areas with heavy vehicle traffic.

All areas that have a high ratio of perimeter edge to surface area (such as sidewalks or any other long, narrow area) should always have insulation under the full slab and on the vertical edge in order to ensure proper performance. Improper insulation in these areas results in much higher operating costs and longer run times. It's easy to spot areas like this because there will be no snow along the sidewalk and the grass will be green and growing in the middle of the winter. That's a lot of wasted energy.

There are also situations where insulation may not be so practical or cost efficient. If a slab is to be entirely frost free and idling at a high temperature, the operating cost difference is not as dramatic as compared to systems that operate in a similar manner with insulation. When the melt surface is paving blocks or asphalt and subject to heavy vehicle traffic it is important to consider the surface loading and weight distribution. In this instance even 100 psi foam board may not be able to carry the load of heavy vehicle tires because the weight is not distributed over a large enough area. If this is the case, insulation should not be used because the foam may compress leaving "potholes" on the surface. This may be both unsightly and dangerous.

Drainage

Melting the snow is only the first step. Allowing the surface to drain properly to get rid of the melted snow is just as important. If there are trench drains in the melt area it is important to keep them free of ice and snow. If these drains become blocked the water can back up onto the melt zone and cause the system to run longer than needed or even overload the system in that area and allow snow or ice accumulation. It is always a good idea to incorporate tubing in these drains to help keep them clear. When installing snowmelt in relatively flat areas it is important to provide slope and drainage. These issues should be discussed and solutions coordinated with the contractor responsible for the installation and finishing of the surfaces.

1. INITIAL CONSIDERATIONS

Loop Patterns

Loop patterns for snowmelt systems are extremely important. Tubing should always be installed in a counter-flow pattern to ensure the most even surface temperature possible. If the tubing is installed in a standard serpentine pattern the surface temperature may vary enough to melt some areas very well and form ice in other areas because the fluid temperature and surface temperatures are too low to provide enough heat to melt at design conditions.

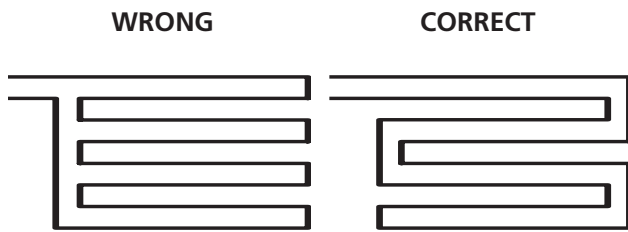

This same pattern must also be used when melting stairs to ensure even temperatures and equal melting. Never make a single tubing pass in a step tread because it is only 10" wide. Stairs have a very high amount of surface heat loss because of the risers, which have no tubing installed. They are also one of the most critical performance areas and deserve special attention. Regardless of the tube spacing for the rest of the project, it's always a good idea to have the tubing on 6" O.C. (or less), if required to get both passes of the loop under the tread surface of the steps.

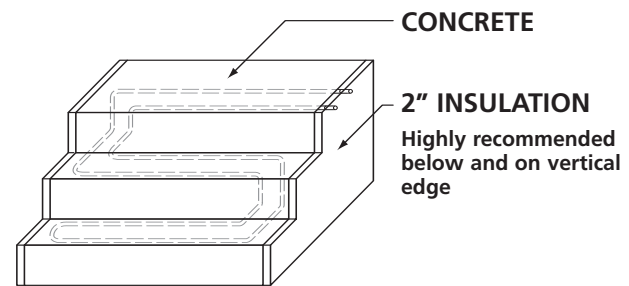

2. SYSTEM DESIGN

Total System Btu/hr Capacity

After you have determined the system performance requirements and the construction of the snowmelt area, consult the charts below to figure out the Btu/sq.ft. required to make the system work. Use the lowest temperature when you can still expect snowfall (or the performance agreed to with your customer) with the appropriate wind speed. Note that every 10 mph increase in wind speed can increase the Btu/sq.ft. heat requirement by almost 50% over the 0 mph wind requirement. In emergency access areas it is prudent to design to the worst conditions but other areas will not require such drastic performance. Be sure to discuss the system performance requirements before starting the design. Please refer to the charts on page 10. One chart is for tubing in a sand bed below paving blocks, asphalt or concrete and the other chart is for tubing placed directly in a concrete slab. Please note that there is a significant increase in performance when tubing is installed directly in concrete because there is much better heat conduction in this system. These charts are based on systems with 1" to 2" of insulation under the slab and on the vertical edge. Allow additional system capacity of up to 33% for

systems without insulation. Please note that these charts show the average water temperature required in the system. The typical fluid design temperature difference for snowmelt systems is 25°F, so the actual supply temperature will be approximately 13°F higher than the average temperature. When you have decided the Btu/sq.ft. output required for your system, multiply this by the total square footage of area to determine the net output required from your heating plant. This number then needs to be corrected for the efficiencies of your boiler.

Total Flow Rate

You can figure the total system flow rate (gpm) by taking the net Btu output of your boiler and dividing by 12,500 (or multiplying by 0.00008) for the flow rate of 100% water at 25°F ΔT. You need to further correct the flow rate for the percentage of propylene glycol in the system by multiplying your gpm of water by 1.05 (30% P-G), 1.10 (40% P-G) or 1.15 (50% P-G). This will give you the approximate total system flow, corrected for the lower heat transfer capacity of propylene glycol solutions, at the same 25°F ΔT.

2. SYSTEM DESIGN

Tubing Selection

After deciding the Btuh/sq.ft. for the project, look at the physical layout to determine a good distribution manifold location. Double the distance from this point to the furthest point away in the system and add 20' to 40' for leaders to get the minimum loop length required. Some systems will require multiple remote manifolds because it is not possible to cover the entire area from one manifold. After determining the minimum required tubing length, consult the following charts relating tubing spacing, tubing length, Btuh/sq.ft. and pressure loss to see which dimension pex will work for your application. Be sure to apply the correction factor for the glycol percentage and fluid temperature of your system! Failure to do so will result in a circulator selection without enough available head and your ΔT will be much higher than anticipated! The difference in the heat transfer between 5/8" tubing and 3/4" tubing is negligible and the length of the loop and amount of heat required will usually drive the selection of tubing size. Typically, 5/8" tubing is used in areas when the average loop length is less than 250' and the heat requirements are less than 120 Btuh/sq.ft. For larger areas, longer loops or higher heat requirements, using 3/4" tubing is the best approach. There are fewer loops and each manifold can serve a larger area.

Total Tubing and Number of Loops Required

After you have determined the tubing size and spacing, you need to figure the actual amount of tubing for the project. If the tubing will be installed 10" O.C. multiply the area in square feet by 1.2 and if the tubing is 6" O.C. multiply the area by 2. Divide this number by the loop length you will be using to get the approximate number of loops required. Remember that you must allow an additional 20' to 40' of leader length for each loop, depending on how quickly the loops can be spread into an effective pattern. You can now divide the total gpm required by the number of loops to get the gpm/loop. As a rule of thumb, 3.0 gpm is the maximum flow for 5/8" tubing and 4.0 gpm is the maximum flow for 3/4" tubing, but the important thing to remember is keeping your pressure loss for each loop well within the available head loss of your system circulator(s) -

don't forget to multiply the head loss in the charts by the adjusting factor for your glycol concentration and operating temperature!

Manifold Selection and Location

In most snowmelt systems the flow required for each manifold is substantially larger than flow available for our standard HK or HKV manifolds. Additionally, 3/4" pex will not connect to our standard manifolds. For smaller systems using 5/8" tubing with total flow rates for each manifold <8 gpm, you can consider the standard manifolds but Roth has 1 1/2" and 2" copper manifolds available for use in commercial heating and snowmelt systems. The larger flow rates available with these manifolds (up to 25 gpm for 1 1/2" and up to 45 gpm for 2") allow you to cover larger areas from a single manifold location. Each manifold has 3/4" male sweat stubs for connecting our sweat ball valves by pex compression adapters. Select the manifold, or multiple manifolds, that best fits your needs.

Manifold location should be selected based on the ability to reach the farthest point in the melt area with the size and length tubing selected. Secondary considerations are what is available in the area to conceal or protect the manifold and proximity to the heating plant. In most instances a single manifold location will save installation time and material, especially if you require underground piping or mechanical vaults for the manifold. If the melt system is adjoining a building and the piping and manifolds can be inside or immediately outside, splitting the system into multiple manifolds may be an advantage.

Some systems require multiple manifold locations simply because of the size or shape of the melt area. Reviewing the site plan will give you the best idea for the number and location of manifolds for the melt area. Manifolds can often be hidden above ground under planters, benches, etc. Using properly covered vaults for in-ground manifolds may be required when there are no available architectural locations. Manifolds can also be ganged up in a single location that requires more flow than a single manifold can provide. In this instance it is important that the supply and return lines to this group of manifolds be properly sized for the required flow and then broken down to feed the individual manifolds.

2. SYSTEM DESIGN

Pumps, Expansion Tanks and Other Accessories

Proper functioning of any hydronic radiant heating system depends on making the correct selection of all of the accessory items. Snowmelt systems depend on proper flow to get the heat out to melt zones. Be sure that when selecting system pumps you have made all of the adjustments for percentage glycol and fluid temperature. Pump performance curves are typically stated for 60°F 100% water. Glycol decreases heat transfer and adds viscosity. Decreased heat transfer requires more flow to achieve the same Btu/hr delivery. Increased viscosity raises the head loss at a given flow rate and the viscosity is temperature dependent. The end result may be a significant change in pump and horsepower requirements. Be sure to make these adjustments before selecting pumps and pipe sizes. As with any other hydronic system, total flow is the sum of all loads; total head loss is the sum of the losses in series

through the system and the worst parallel branch. The correction charts here apply only to the tubing. Be sure to consult your pump supplier if you have any questions regarding selection, performance and capacity.

Selection of the expansion tank(s) for the system depends on type of fluid, total fluid content of the system, operating temperatures, fill and operating pressures and boiler relief valve setting. You can get the approximate volume of fluid content from the chart shown later. The other information is dependent on the system and equipment you will be using. Consult your expansion tank provider for the correct selection for your project.

Other critical accessory items include heat exchangers, air eliminators, control valves, suction diffusers, etc. Consult your supplier for more information on these items.

3. EXAMPLE CALCULATION

You are to provide a snowmelt system for a 100' x 100' pedestrian plaza with brick pavers over a sand bed with 2" insulation under the area and on the vertical edge. Only light maintenance vehicles will be permitted in this area and it is not critical to keep the area completely clear under any conditions. Some snow accumulation will be permitted during heavy snowfalls, but it is expected that the area will be generally free of snow and ice during "normal" conditions. It rarely snows in this location if the temperature is below 20°F and the temperature never drops below -5°F. The system will have a separate heating plant and is expected to operate without supervision. The mechanical room will be at the center of one of the boundaries of the melt area with all equipment and manifolds located in the room.

Equipment Size

When you check the chart for Heat Output and Fluid Temperature for tubing in a sand bed under brick pavers you can see that at +10°F with a 10 mph wind you need approximately 100 Btu/sq.ft.. Total system output required for this system will be a minimum of 1,000,000 Btu/hr. Remember that this is NET OUTPUT of the heat-

ing plant. The heating fluid will be a solution of 40% propylene-glycol and water, providing freeze protection to a temperature of approximately -10°F. Total system flow rate at a 25°F drop across the system will be about 1,000,000 (Btu req'd) / 12,500 (system flow at 25°F ΔT) x 1.10 (flow correction for 40% P-G) = 88 gpm total flow.

From the same chart we can see that the average fluid temperature should be 99°F. The supply temperature is now 99°F (average fluid temp) + 12.5°F (1/2 of the ΔT) = 112°F.

Tubing Selection

Since the Btu/sq.ft. requirements are relatively low, we will use 10" tube spacing. Multiply area by the factor in the tube spacing chart to get the total amount of tubing for the project (10,000 x 1.2 = 12,000' of tubing). Based on a single manifold location it will take a minimum of 300' of tubing to reach the furthest point in the melt area. With the leader length added, the total loop length will be approximately 330'. Due to the relatively short loop length and low Btu/sq.ft. requirements of the system, we can use 5/8" pex tubing. 12,000' / 300' loops = 40 loops for the

3. EXAMPLE CALCULATION

system. $88 \text{ gpm total flow} / 40 \text{ loops} = 2.2 \text{ gpm}$ flow per loop. This selection will be well within the earlier guidelines and we can proceed with the design.

Loop Head Loss

Consult the chart for tubing on 10" centers to get the head loss for each loop. In this case, we look for ~100 Btuh/sq.ft. under the 5/8" tubing and we see that there is about 18-20' of head loss for each loop, assuming that all loops are approximately the same length. This value is for 100°F water. We then look at the correction chart and see that for an average water temperature of ~100°F and 40% P-G the correction factor is 1.35. The actual head loss for each loop is $19' \times 1.35 = 26'$ for the loops. Add this to the other piping losses in the system to get the total head requirement for your system circulator.

Manifold Location

The project allows us one manifold location in the mechanical room. We have a limit of approximately 40-45 gpm per 2" manifold fed by a 2" copper line. In this project the total flow required is ~88 gpm, therefore, we will need two manifolds. These manifolds can be installed adjacent to each other and fed by common supply and return mains. These mains will need to be sized for the total flow and two 2" branches installed to feed each manifold.

Expansion Tanks and Other Accessories

You can calculate the fluid content of the system by using the chart for fluid volumes of various size pex, copper tubing and pipe. In this case, we have 40 loops of 5/8" pex approximately 330' long. The total fluid content of the pex is $40 \text{ (loops)} \times 330' \times 0.0134 \text{ (US gal/ft)} = 177 \text{ US gallons}$. You need to add the volume of all of the piping, boiler, etc. to get the total system volume. You now have the information to size your expansion tank (fill temperature, operating temperature, fill pressure, relief valve setting, fluid type and system volume). Your supplier can now provide the appropriate expansion tank for your system.

With the total system volume you can now calculate how much propylene-glycol you need to get

the approximate concentration for the project. Be aware that P-G is available in several pre-mixed concentrations and you may need to make further corrections to the quantity of glycol required based on the concentration that is available. After the glycol is installed be sure to follow the manufacturer's instructions to verify the concentration (refractometer, etc.).

The total system flow will also allow the selection of the most effective air eliminator for the project. Consult your supplier for information.

3. EXAMPLE CALCULATION

Controls

This customer has requested a fully automatic system. These systems usually include a snow/ice detector, slab sensor, outdoor air temperature sensor, system supply and return sensors, etc. These controls can automatically start the system, including boiler(s) and pumps (motor starters may be required), when there is snow or ice on the ground. They can also "idle" the system to provide very quick response when melting is required and they can control the mixing device that provides the correct fluid temperature to the system. These controls are more expensive than manual controls but they provide a much more efficient and effective system than manual controls. Control selection should be based on the needs and expectations of the customer.

HEAT OUTPUT AND FLUID TEMPERATURE for tubing installed in the middle third of a 4" to 5" thick concrete slab				
Outdoor Temp (°F)	Wind Speed (mph)	Heat Output (btu/hr/sq ft)	Average Fluid Temp Required (°F)	
			6" O.C.	10" O.C.
+10	0	49	53	60
+10	10	100	70	83
+10	20	150	84	
0	0	68	59	69
0	10	134	81	99
0	20	202	101	
-10	0	87	66	78
-10	10	170	92	115
-10	20	255	117	
-20	0	109	73	88
-20	10	204	102	130
-20	20	307	133	

HEAT OUTPUT AND FLUID TEMPERATURE for tubing installed 1" down in a sand bed with 3" of asphalt, concrete or paver blocks above				
Outdoor Temp (°F)	Wind Speed (mph)	Heat Output (btu/hr/sq ft)	Average Fluid Temp Required (°F)	
			6" O.C.	10" O.C.
+20	0	31	53	57
+20	10	65	70	78
+10	0	48	63	69
+10	10	100	87	99
0	0	68	72	81
0	10	135	104	121
-10	0	88	82	93
-10	10	170	121	142

Nom. Size Inches	Roth Pex Tubing		Type L Copper Tubing		Standard Steel Pipe	
	US gal/ft	liters/meter	US gal/ft	liters/meter	US gal/ft	liters/meter
	3/8"	0.0049	0.061	0.008	0.099	
1/2"	0.0092	0.114	0.013	0.161	0.016	0.199
5/8"	0.0134	0.166	0.018	0.224		
3/4"	0.0184	0.228	0.027	0.335	0.028	0.348
1"	0.0304	0.378	0.045	0.559	0.045	0.559
1 1/4"			0.068	0.844	0.078	0.969
1 1/2"			0.095	1.180	0.106	1.316
2"			0.165	2.049	0.174	2.161
2 1/2"			0.248	3.080	0.249	3.092
3"			0.354	4.396	0.384	4.769
4"			0.622	7.724	0.661	8.208

FREEZE PROTECTION OF PROPYLENE-GLYCOL AND WATER SOLUTIONS (by volume)				
% Conc	30%	40%	50%	60%
Freeze Pt	+8°F	-7°F	-28°F	-60°F

FEET OF TUBING REQUIRED BASED ON TUBE SPACING	
Tube Spacing on Center	Multiply Area by this Factor
6"	2.00
8"	1.50
9"	1.33
10"	1.20
12"	1.00
18"	0.67
24"	0.50

Be sure to add 20' to 40' to each loop for leaders!

3. EXAMPLE CALCULATION

Head Loss by Loop Length and Btuh/sq.ft. for 5/8" and 3/4" pex with 10" Tube Spacing (100°F Water)

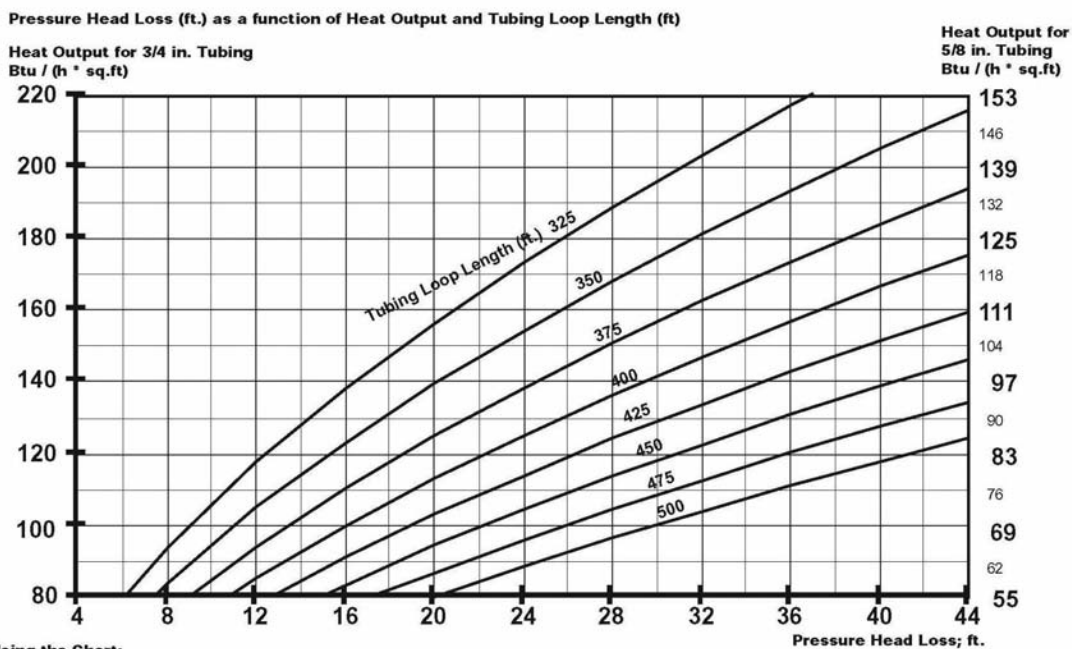
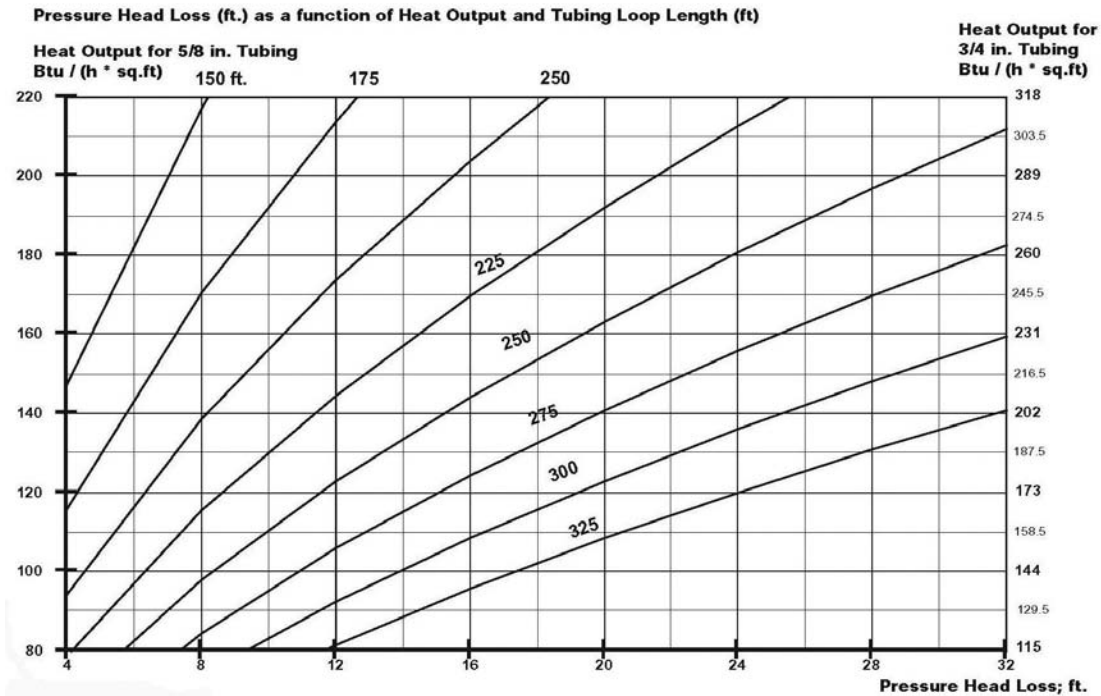

Using the Chart:

- Use the upper chart for shorter loop lengths and the lower chart for longer lengths.
- The BTUH/sq ft output for 5/8" or 3/4" tubing are listed on the left or right hand sides of the chart.
- Find the required BTUH/sq ft output under the tubing diameter you are using and move either left or right across the chart to your approximate loop length, then move down to find the pressure drop for each loop.
- Please note that you must manually calculate all other losses in your system to know the total pressure loss.

Note: 1 psi = 2.3 ft. Pressure Head Loss

Design Base and Design Considerations

- These charts are valid for 100% water at 100 degrees F.
- See the chart at the end of this section to get the correction factor for propylene glycol solutions and different temperature fluids.
- Multiply the head loss from this chart by the correction factor to get the actual loss.

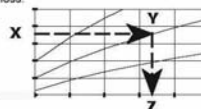

Note: For projects with design data not covered by this Chart: Call Roth at 888-266-7684, and we will fax or mail the chart that you need.

3. EXAMPLE CALCULATION

Head Loss by Loop Length and Btuh/sq.ft. for 5/8" and 3/4" pex with 6" Tube Spacing (100°F Water)

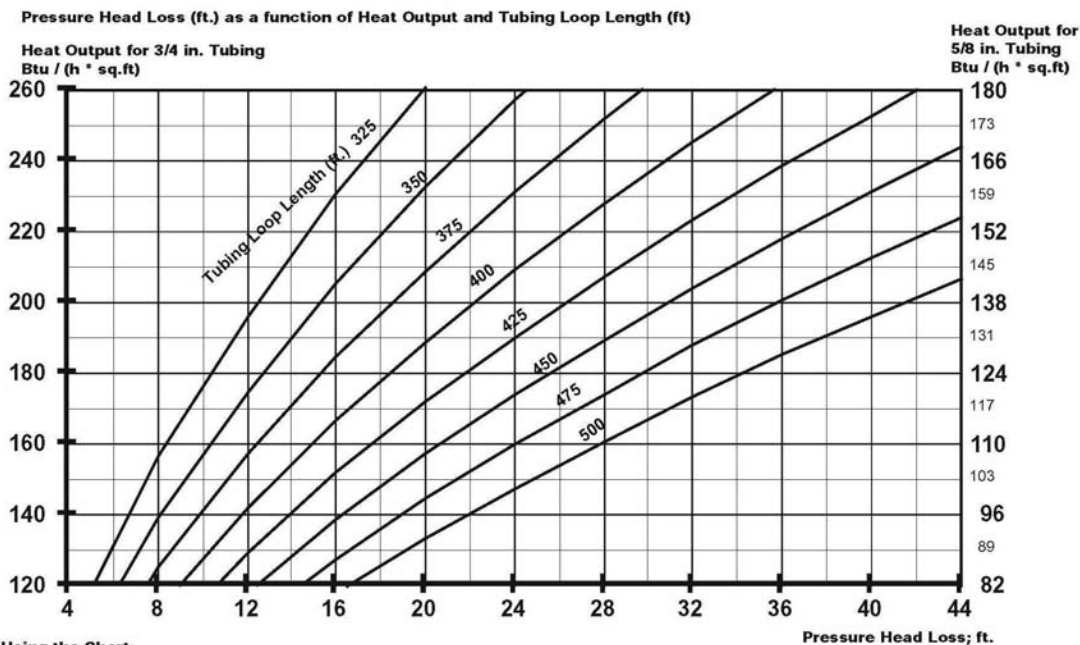
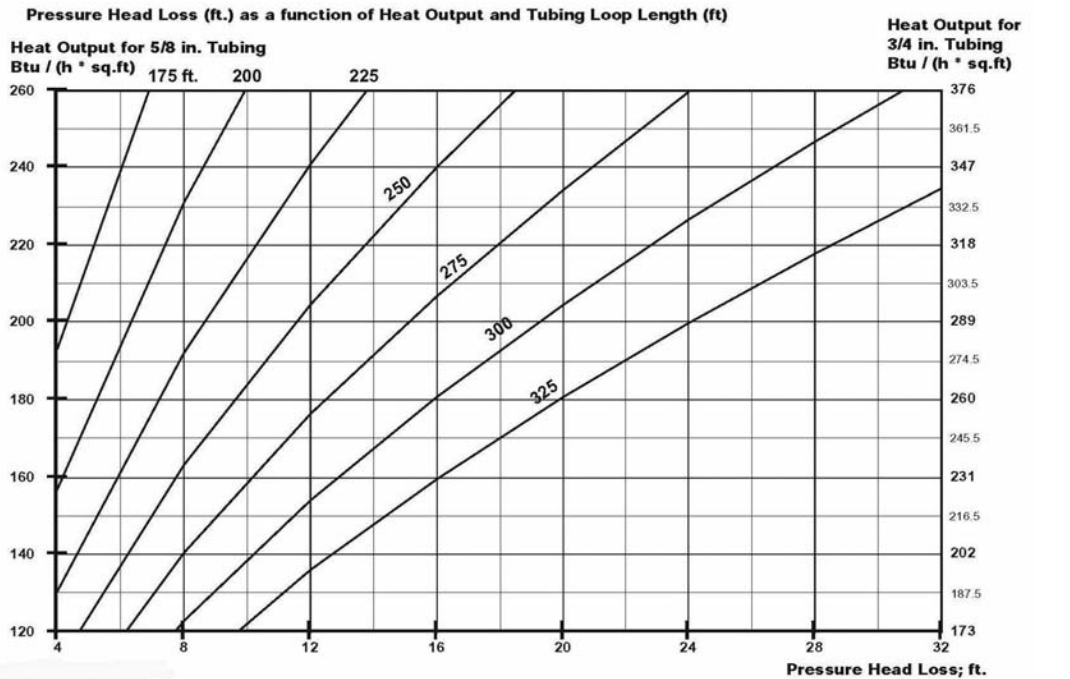

Using the Chart:

- Use the upper chart for shorter loop lengths and the lower chart for longer loop lengths.
- The BTUH/sq ft outputs for 5/8" or 3/4" tubing are listed on the right or left hand sides of the charts.
- Find the required BTUH/sq ft output under the tubing diameter you are using and move either left or right across the chart to your approximate loop length, then move down to find the pressure drop for each loop.
- Please note that you must manually calculate all other losses in your system to know the total pressure loss.

Design Base and Design Considerations

- These charts are valid for 100% water at 100 degrees F.
- See the chart at the end of this section to get the correction factor for propylene glycol solutions and different temperature fluids.
- Multiply the head loss from this chart by the correction factor to get the actual loss.

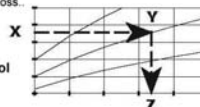

Note: For projects with design data not covered by this Chart: Call Roth at 888-266-7684, and we will fax or mail the chart that you need.

Note: 1 psi = 2.3 ft. Pressure Head Loss

3. EXAMPLE CALCULATION

Head Loss Correction Factors for Propylene Glycol by Concentration and Average Temperature

Pressure Head Correction Factor (multiplier) as a function of Average Fluid Temperature (°F) and Propylene Glycol Concentration (Volume %)

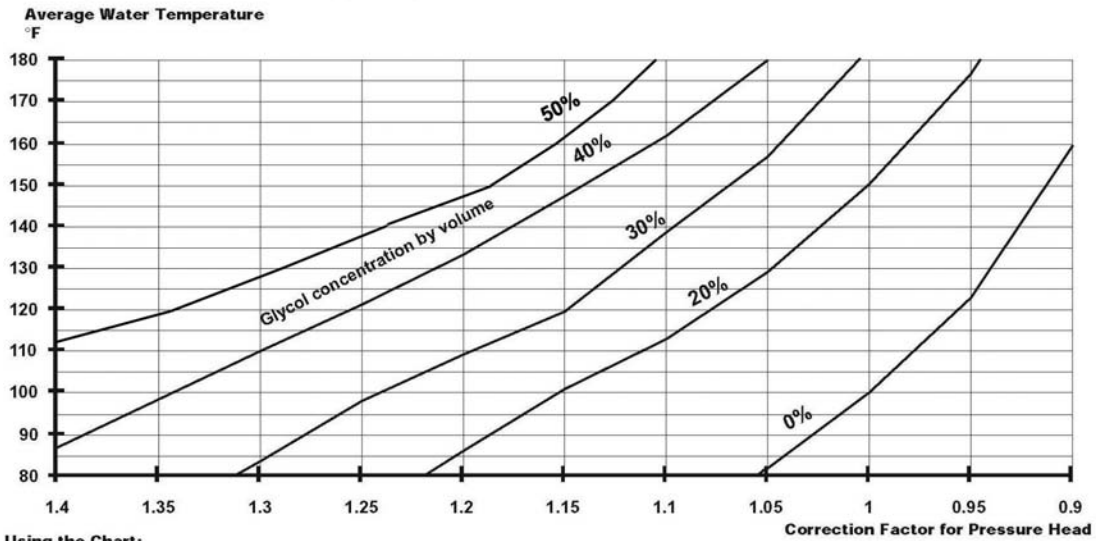

Using the Chart:

- Find the Average Water Temperature to the left
- Move horizontally right until the intersection with actual Glycol concentration.
- Go down vertically and read the Head Loss Correction Factor.
- Multiply Head Loss (ft.) with the Correction Factor for correct result.

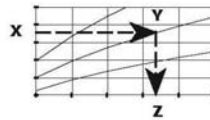

4. SAMPLE INSTALLATION — CROSS SECTIONS

Concrete

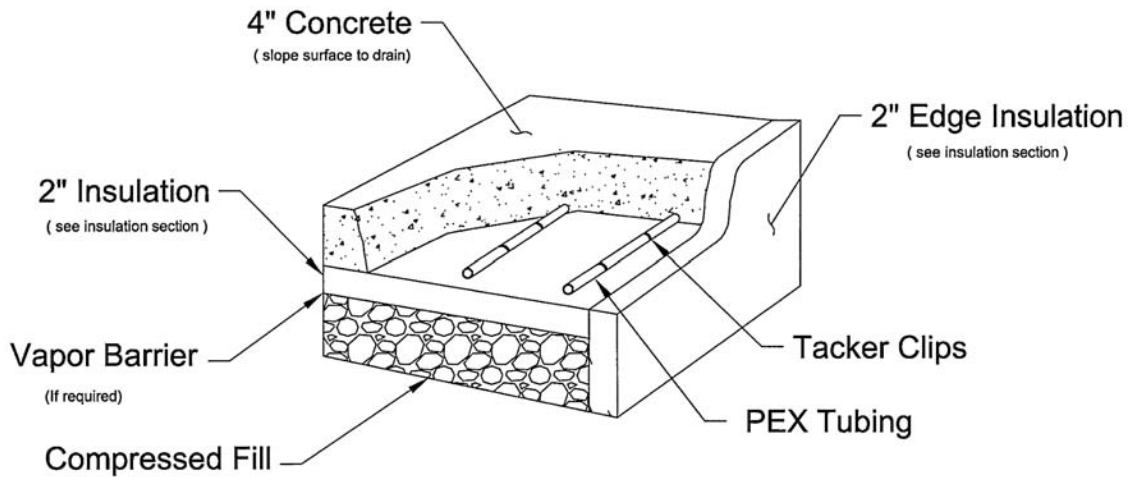

Asphalt

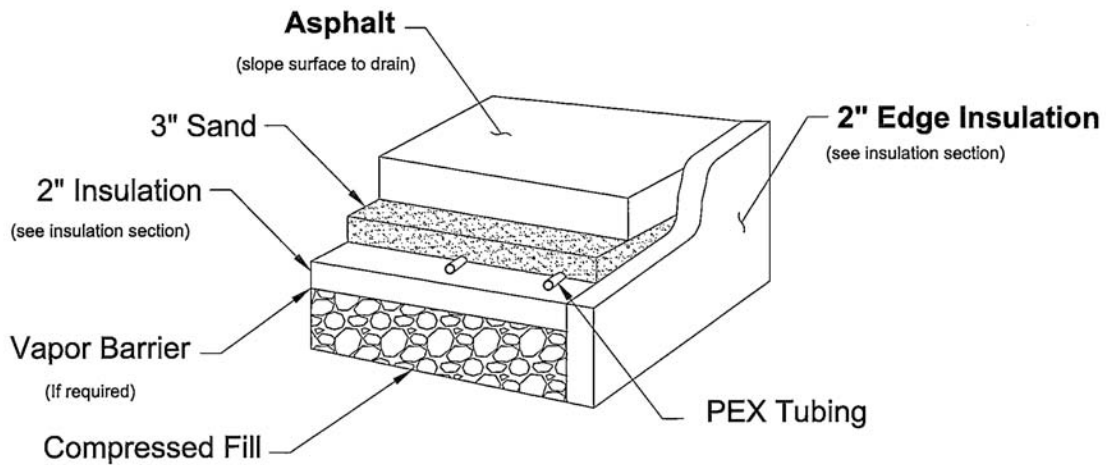

Paver

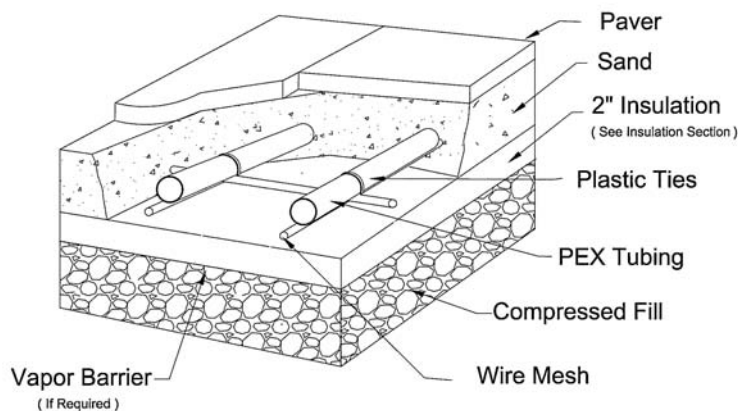

5. SUMMARY

There are many other options and considerations when designing and installing a snowmelt system. This exercise is just an example of what can be done and how to do it. Our software will allow the selection of three levels of performance (residential, commercial and industrial) for each system that you design with different tube sizes and spacing. This will ensure that the system will perform for every level from a residential driveway to an emergency access area. We recommend that you use the software to make system design easier and faster, these guidelines will allow you to design simple systems without much difficulty.

If you have any questions about snowmelt design, you can contact the Roth office in your area.



PRINTED IN CANADA - EM316 05/05

Roth's success is the result of product flexibility, targeted investments and theme-oriented solutions. Our growth stems from continuous research and the development of new and innovative products. The keys to our success in manufacturing include know-how, modern production sites and equipment, the very latest production technologies, and highly motivated personnel.

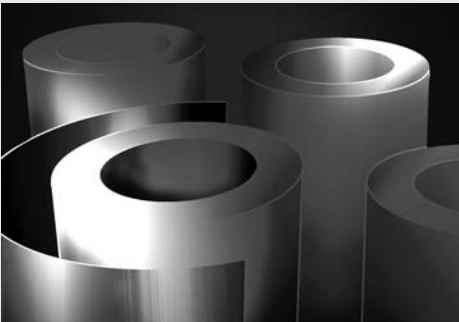

North America

U.S. Roth Industries, Inc.
 77, Circuit Drive
 North Kingstown, Rhode Island 02852
 Phone: (401) 267-9044
 Fax: (401) 267-9048
 info@roth-usa.com
 www.roth-usa.com

